



JenAct

JenAct UV Disinfection Conveyors

Part of *The Jenton Group*

JenAct – Part of the Jenton Group



JenAct

The Jenton Group



- Trading since 1973
- Experts in developing special-purpose machinery
- Group companies:
 - **Jenton International**
 - UV curing systems, banding machines, custom engineering with in-house R&D
 - **Jenton Ariana**
 - Manufacturer of UV conveyors and food automation systems
 - **JenAct**
 - UV disinfection systems, microwave UV, systems for treatment of odours/VOCs
 - **Dimaco UK**
 - Label inspection systems

**JenAct have been
designing UV
disinfection
devices since
1994**



JenAct



The Science

UV-C light has been used for over 100 years to disinfect surfaces and air.

Ultraviolet light is a wavelength of light that is shorter than visible light but longer than X-rays. The UV-C band of ultraviolet light has been known for its germicidal properties for over 100 years and was first implemented to reduce the spread of TB in hospitals.

UV-C light is high energy and is absorbed by the RNA and DNA of viruses like Covid-19. It is also effective against bacteria and fungal spores. When too much energy is absorbed by the virus DNA it damages the nucleic acids, making the microorganisms unable to infect or reproduce.

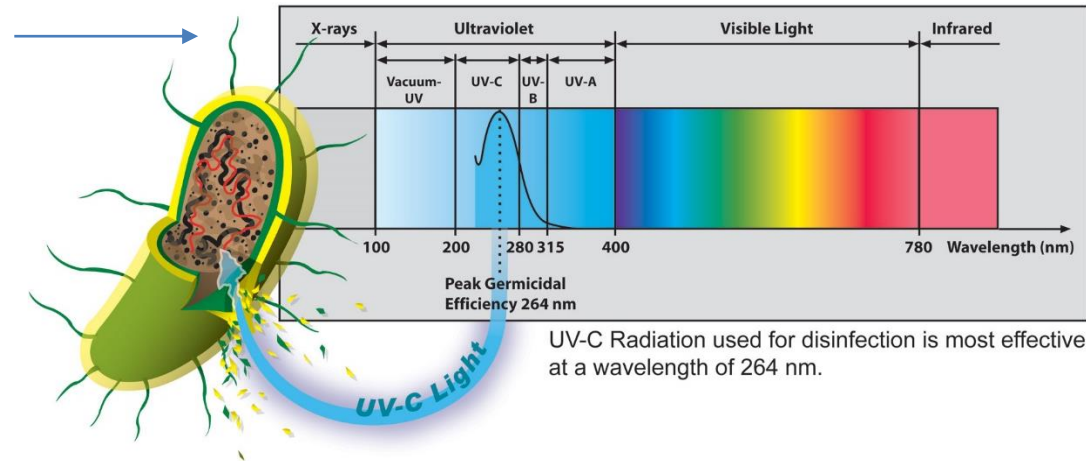
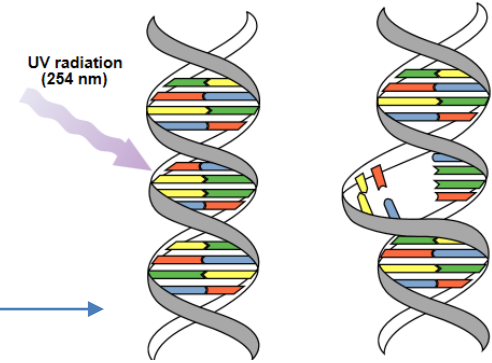

The Limitations

UV-C light is unable to penetrate many materials, including most glass, plastic films and even small pieces of dirt.

In addition, one must consider shadowed areas, such as handles, folds, straps etc.

Shadowing can be an issue in UVC disinfection when the system is designed to cope with a large variety of complex objects.

When designing UV systems we position the UVC lamps in such a way to minimize this effect as much as possible, but on occasion you can get cold spots where the UV light is unable to reach the surface. UVC must reach the DNA that it is intended to disrupt.

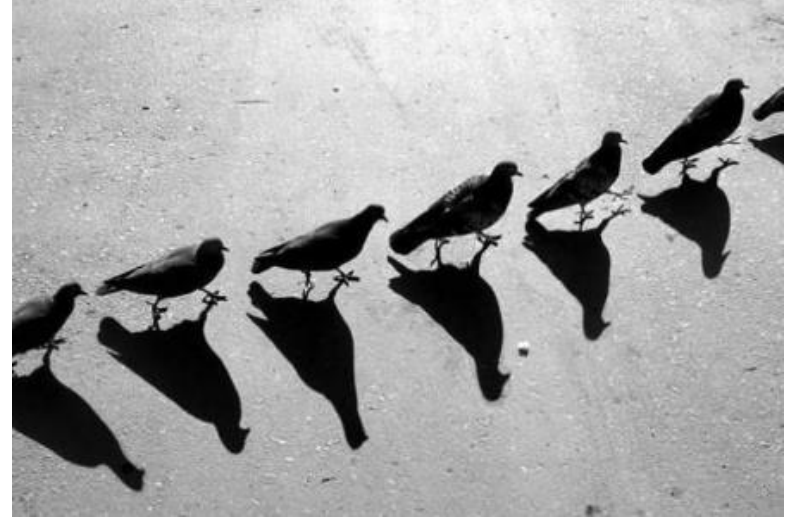

UV Conveyors

Very often the best way to evenly expose items to UV is on a conveyor.

Longitudinally mounted lamps in reflectors that present an even UVC distribution over width and height allow an even exposure to UV and exposure time is simply controlled by conveyor speed.

We can achieve disinfection rates of 99.99%+ on exposed surfaces.

Jenton have designed and made many UV conveyors, for food and medical applications.

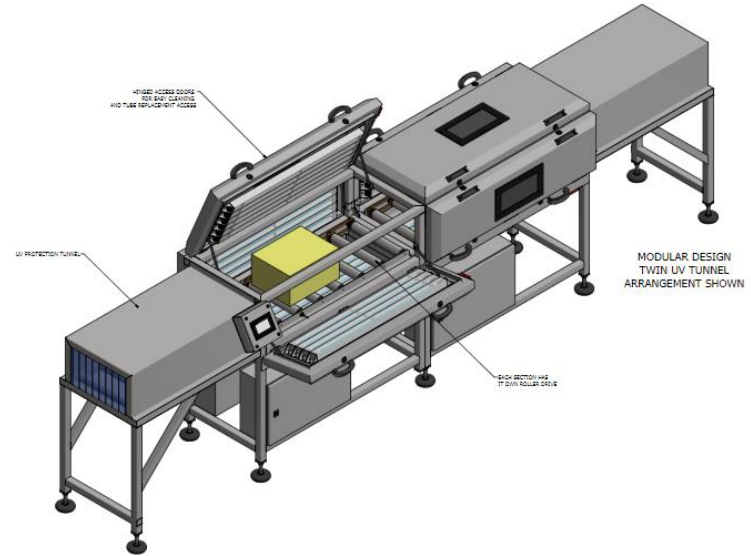

Conveyor Size

Conveyors are available in a wide variety of sizes and configurations to accommodate all types of applications.

These can be standalone or integrated into existing systems.

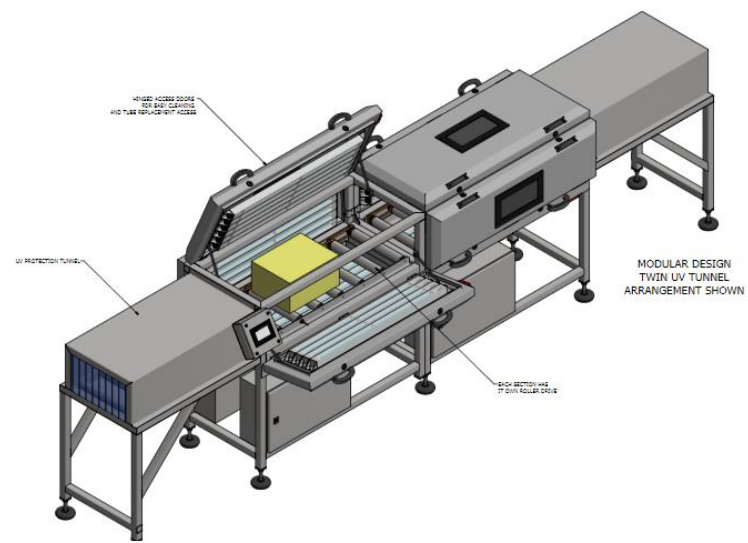

Design

Design is carried out in-house to suit the requirements of the customer

Consideration is given to length, width, speed (variable), torque, airflow, cooling, lamp height (variable), infeed and outfeed connectivity, E-stops, interlocks, lamp control.

Systems are typically designed for a **log 3 (99.9%)** or **log 4 (99.99%)** reduction in pathogens on exposed surfaces.

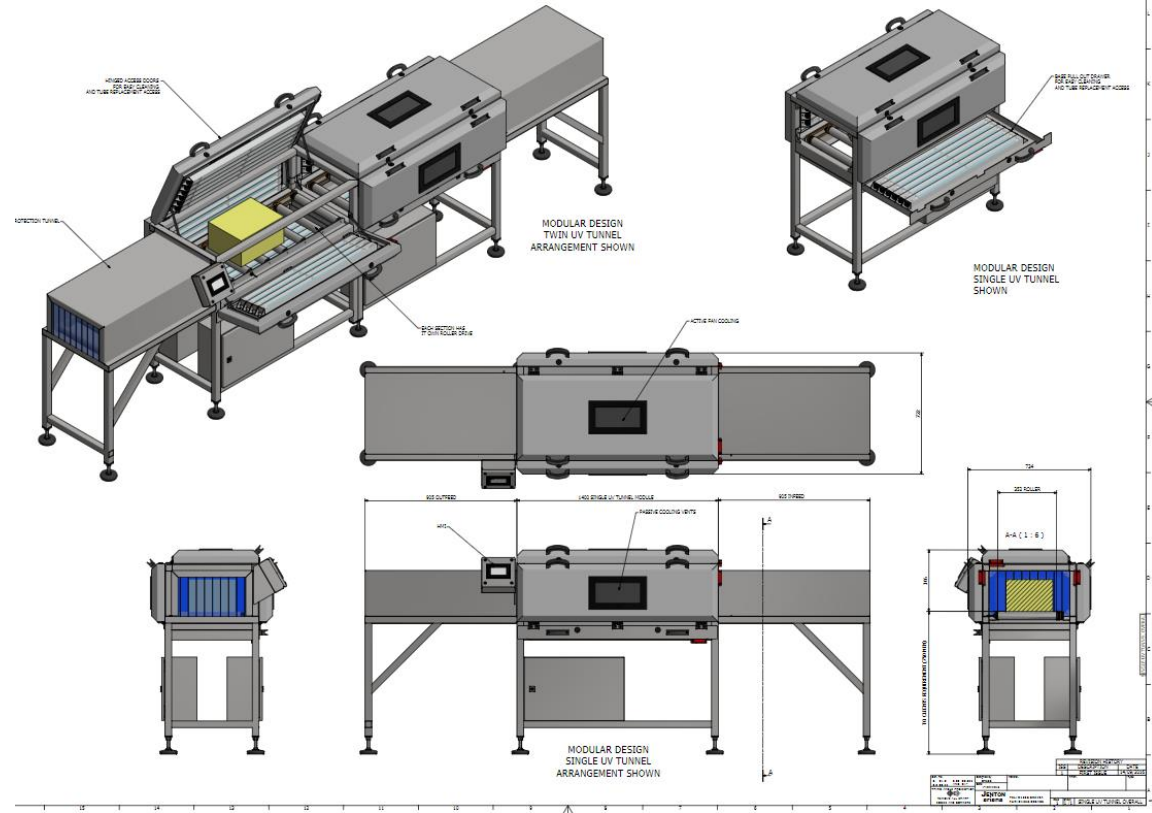

Roller Conveyor detail

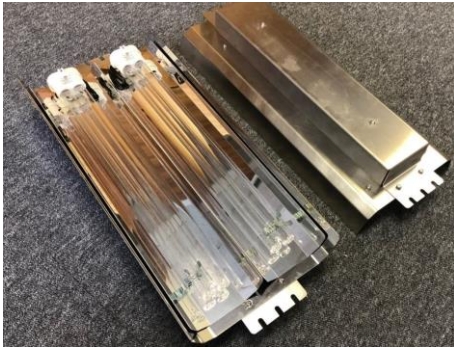

Flat belt detail

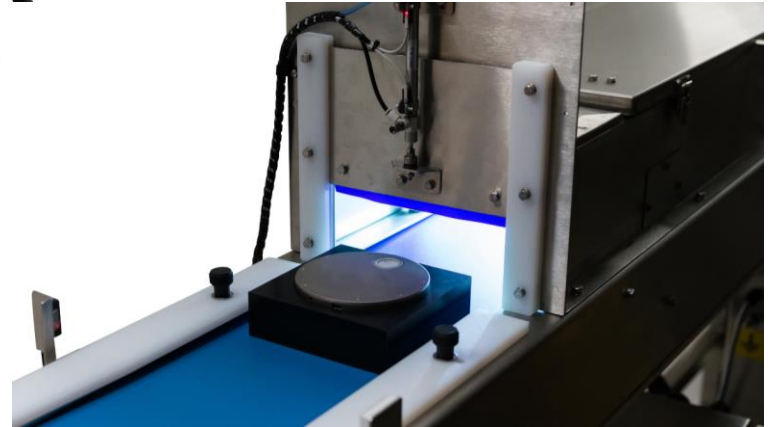

Wire belt detail





JenAct

Contact Us

Tel: 01234 123 4567

Email: jenact@jenton.co.uk

Visit: www.jenact.co.uk