

Excellence in Food Packaging Automation



Jenton *ariana*

Ariana became part of the Jenton Group in 2005. Jenton Ariana are specialists in food packaging automation including convergers, seal testers, stackers, pad placers and line control.

Jenton Ariana equipment works in line, at high speed, with rollstock thermoformers and tray top sealers. 2/3 and 2/3/4 lane switchable convergers are available. Random infeed and wet products can be accommodated. Stackers can stack for banding or batching. Jenton Ariana understands that line length = cost. Systems are compact and easy to use and maintain.

Jenton Ariana offers bespoke design possibilities, whether customers are retail, manufacturing or production orientated. Our design team is always ready to discuss your application. All our products started life as a solution to someone's problem.

Jenton is a ISO 9001 company. All machines are designed and manufactured at our facilities in Hampshire, England to the highest professional standards using food grade materials.

Food packaging automation including convergers, seal testers, stackers, pad placers and line control

Jenton Ariana manufacture a wide variety of automatic stacking systems



Our **bespoke design** possibilities allow **integration** with equipment from other manufacturers

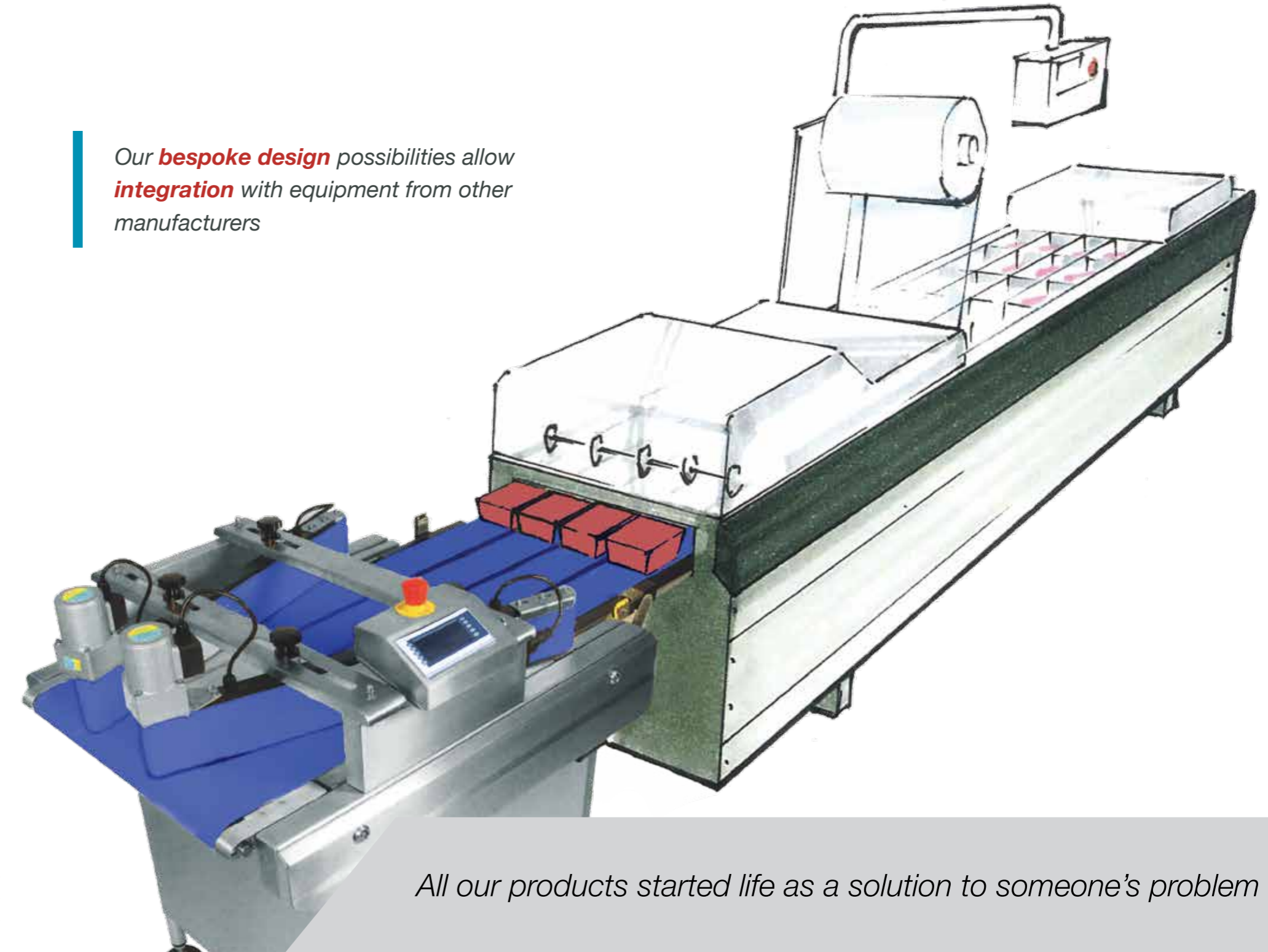

All our products started life as a solution to someone's problem

Automatic Pad Placers for Tray Sealers and Thermoformers



Jenton *ariana*

Our machines are designed to have as small a footprint as possible and yet are capable of loading up to 180 pads per minute.

NEW
Plastic free
pads
available

Jenton Ariana 'Autopad'

Our biggest selling padding machine is the Autopad pad placer for tray sealers using pre-cut pads. The interchangeable pad cassettes make this machine ideal for multi product lines, even when a variety of pads are used. Changeover of cartridges from one size to another takes only a couple of seconds.

Advantages

- Very easy to set up using the colour touchscreen
- Simple connection to tray sealer / thermoformer
- Minimum footprint
- Very simple with easy access

The Automatic Pad Placer is without doubt the most efficient way to ensure complete pad placing in trays



Features

- Operates at approx 20-25 cycles per minute
- Machines are available for pre-cut and roll-fed material
- Pad missing / misfeed alarm
- All stainless steel construction up to IP67

Benefits

- Practically eliminates trays without pads
- Most hygienic pad placing eliminates manual pad placing
- 'Fit and forget' operations



Jenton Ariana,
Autopad

Interchangeable pad cassettes make this ideal for multi product lines