

# Pouch and Bag Sealers

From Jenton International



# Jenton Group

Since 1973

UK SME business based in  
Whitchurch, Hants, UK

Specialising in the design,  
manufacture, supply and support of  
products for the following  
industries;

Packaging (Banding and Sealing)

Food packaging automation

UV Curing (industrial and medical)

UV Disinfection (air and surface)

Label and Data verification



# Two brands – maximum options



## **Emplex – by Plexpack** (Canada)

Bench, floor standing, integrated bag sealers for individual bags and pouches.



## **Pronova** (Sweden)

Inventors and innovators of the JOKER® concept.

Automatic bag feed for hand or automated filling.

*These two ranges give every option from when a simple hand sealer is no longer enough. Many options from small bench top units to automated feed and fill systems. Dry goods, medical, and food.*



Static bench top and floor standing sealers for sealing of individual bags with vacuum and gas flush.

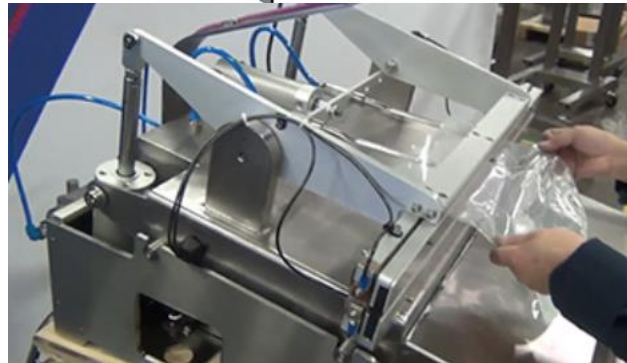
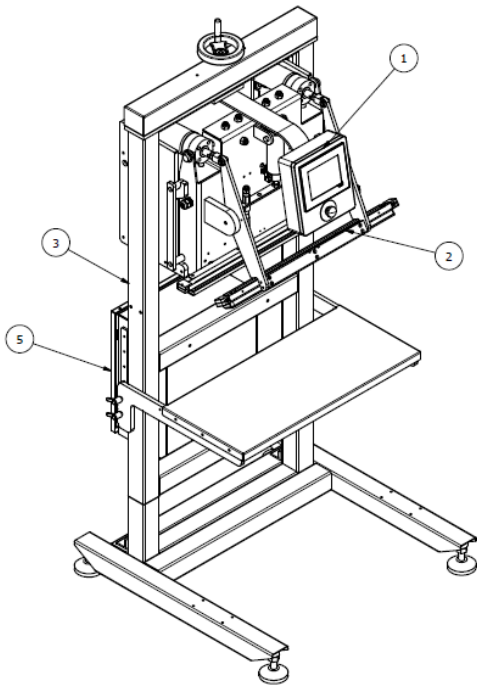



Bench top and floor standing hand fed Continuous band sealers for bags and pouches. Vacuum and gas flush possible also. (conveyorised for heavier items)





In 1980, Pronova invented a unique packaging concept named JOKER®. Since then they have manufactured packaging machines and linked bags to create a cost efficient and automated packaging system



# Bags and Pouches



LDPE, Laminates, Doybags, zipper and even plastic free.

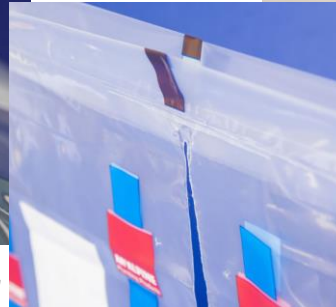

Bags by:



Bags and pouches for JOKER® are made by Supreme Plastics in Whitby, UK





**EARTHPOUCH/PLASTIC-FREE RECYCLABLE & SUSTAINABLE STAND-UP PACKAGING POUCH**



The stable high temperature and high pressure seal from EMPLEX is perfect for EARTHPOUCH

Earthpouch from SIRANE is 100% plastic free and can be heat sealed and recycled with paper.



Jenton International have been supplying bag related machinery since the 1970s. We can advise and supply customers on methods, machines, materials and supply service and spare parts.

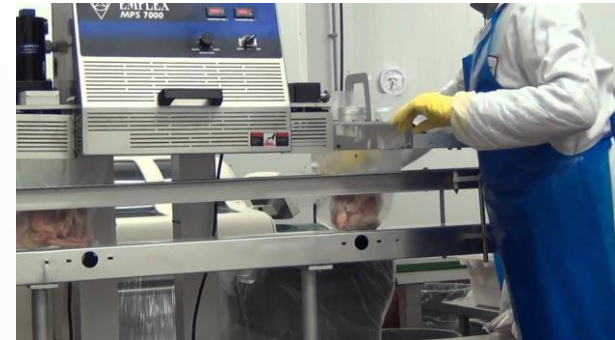

Ask us for full details on

**PRONOVA**  
PACKAGING SYSTEMS

**PLEXPACK**  
Flexible Solutions. Certain Results.™



products



***Jenton***

**sales@jenton.co.uk**

**01256 892194**

**www.jenton.co.uk**

Founder Member

