

Pouch and Bag Sealers

From Jenton International



Jenton



Jenton Group

since 1973

UK SME business based in
Whitchurch, Hants, UK

Specialising in the design,
manufacture, supply and
support of products for the
following industries;



- Packaging (Banding and Sealing)
- Food packaging automation
- UV Curing (industrial and medical)
- UV Disinfection (air and surface)
- Label and Data verification



Two brands - maximum options

These two ranges give every option from when a simple hand sealer is no longer enough. Many options from small bench top units to automated feed and fill systems. Dry goods, medical, and food.

PLEXPACK
Flexible Solutions. Certain Results.™



Emplex – by Plexpack (Canada)

Bench, floor standing, integrated bag sealers for individual bags and pouches.

PRONOVA
PACKAGING SYSTEMS



Pronova (Sweden)

Inventors and innovators of the JOKER® concept.

Automatic bag feed for hand or automated filling.



Emplex – by Plexpack (Canada)

Static bench top and floor
standing sealers for sealing of
individual bags with vacuum
and gas flush.

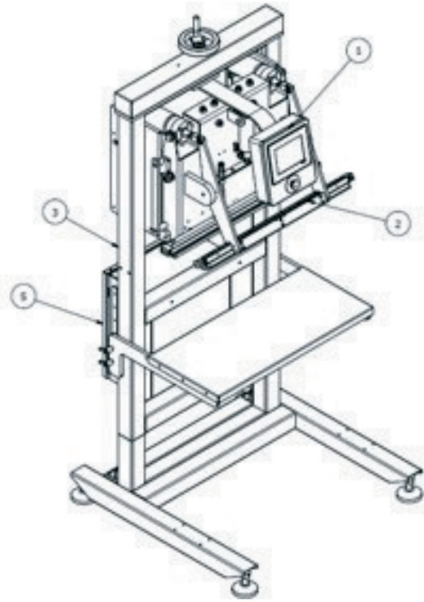



Emplex – by Plexpack (Canada)

Bench top and floor standing hand fed Continuous band sealers for bags and pouches. Vacuum and gas flush possible also (conveyorised for heavier items).





Pronova (Sweden)

In 1980, Pronova invented a unique packaging concept named JOKER®. Since then they have manufactured packaging machines and linked bags to create a cost efficient and automated packaging system.



PRONOVA
PACKAGING SYSTEMS

Products packed on Pronova

DIY

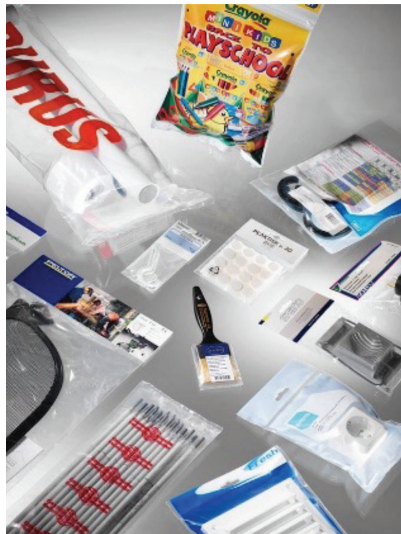

- Brushes
- Plumbing parts
- Shower hoses
- Screws/nuts
- Electrical components
- Spare parts
- Kitchen supplies
- Furniture supplies

FOOD



- Frozen food
- Ready to cook
- Health food
- Flour
- Hot-fill
- Herbs
- Multipacks
- Petfood
- Dog and Cat treats
- Protein powder
- Rice

PHARMA



- Dental products
- Medical jars
- Face masks
- Nursing pads
- Medical supplies
- Medical
- Lab supplies
- Supplies for food diagnostics

HOUSEHOLD

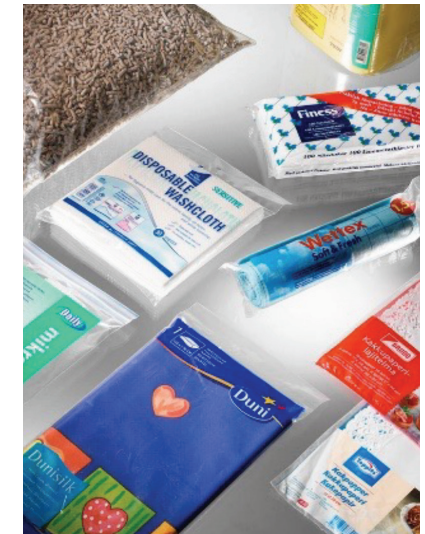

- Wet wipes
- Diapers
- Napkins
- Pellets
- Toys
- Table decorations
- Office articles / Pens
- Sanitary supplies
- Shoe insoles



Bags & Pouches

LDPE, Laminates, Doybags, zipper and even plastics free

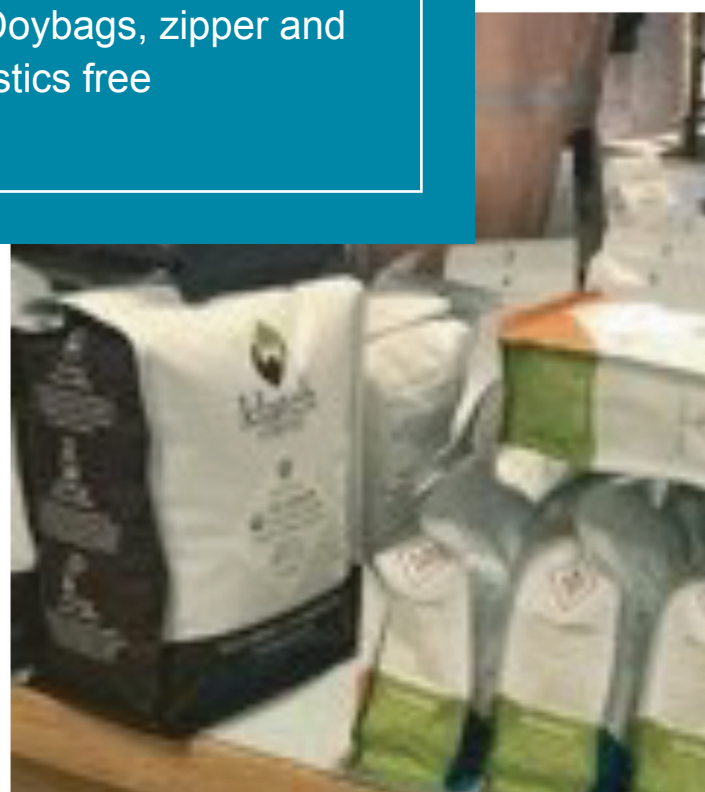



Joker® Bags by Roberts Mart

Bags and pouches for JOKER®
are made by Roberts Mart in
Leeds, UK.





Jenton Group

Excellence in packaging and UV

Jenton International have been supplying bag related machinery since the 1970s. We can advise and supply customers on methods, machines, materials and supply service and spare parts.



Ask us for full details on:

PLEXPACK
Flexible Solutions. Certain Results.™

PRONOVA
PACKAGING SYSTEMS

RM
Roberts Mart

JENTON GROUP

SINCE 1973



Specialising in the supply and support of products for the following industries:

Packaging

UV Curing and Converting

UV Disinfection

Software

We offer design and consultancy services in addition to machinery sales and have fully equipped service, workshop, laboratory and demonstration facilities.

Packaging

Jenton Ariana - Food Packaging Automation
ATS - Ultrasonic Seal Banding Machine
Proband - Ultrasonic Seal Banding Machine
StraPack - Heat Sealing and Automatic Banding Machine
Jenton Bandit® - Heat Seal Banding Machines
Plexpack Emplex - Bag Sealers - Food and other industries
Controls Engineering LLC - Stretch Film Banders
Jenton Dimaco - Label and Data Verification

UV Curing and Converting

Excelitas (formerly Lumen Dynamics) - UV Spot Curing and LED Curing Equipment
EMI - UV Cured Adhesives, Epoxies and Coatings
EIT - UV Radiometers
Jenton UV - Modular UV Curing Lamps and Power Supplies
opti-color Ink Control Systems
Jenton UV Conveyors - Laboratory and Production Conveyors

UV Disinfection

JenAct UV - UV Disinfection, UV Surface Sterilisation and Microwave UV Technology
Xenon - UV Based Vitamin Enhancement

Software

Expidero - Custom Software

Founder Member



www.jenton.co.uk



Jenton

sales@jenton.co.uk

01256 892194

www.jenton.co.uk

Founder Member

