



Jenton UV

JentonUV
UV conveyors

Production and laboratory UV curing conveyors

**Jenton
International** have
designed and supplied
UV curing systems for
engineering, coating,
medical and print
applications since
1979



Jenton UV

This includes:

- Arc lamp systems
- Microwave lamp systems
- Spot cure systems
- LED curing systems
- Xenon pulsed UV systems

- UV Ovens
- UV conveyors
- Custom engineering

- UV radiometers
- UV cure adhesives

The science

UV light, typically between 250 and 400nm initiates a polymerization reaction in a liquid which turns it into a solid. That liquid can be an ink, adhesive or coating.

At *JentonUV*, our job is to;

- a) Select the most appropriate wavelength output, type and power of UV lamp/LED system.
- b) Specify or design the most efficient and effective way to mount and protect that light source and to transmit that light to the material to be cured.

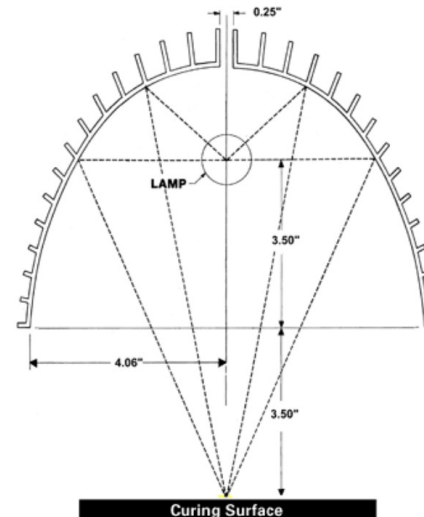
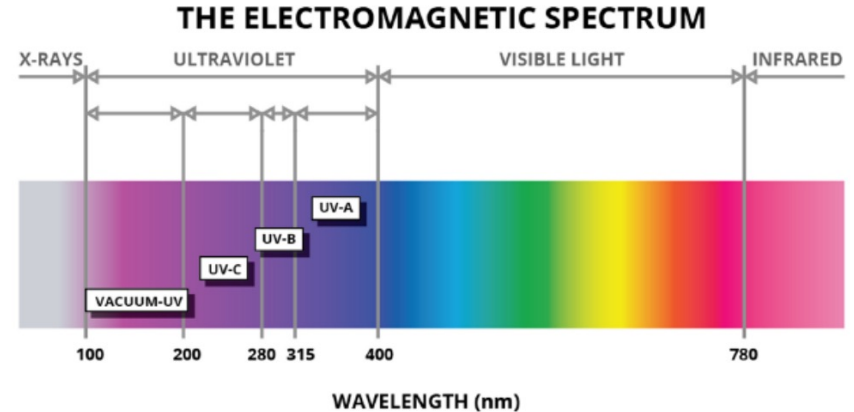

UV Conveyors

Very often the best way to evenly expose items to UV is on a conveyor.

In almost all cases the UV light output from a lamp or LED is even along it's length.

By mounting the lamp perpendicular to the belt direction and controlling the speed, very even and accurate exposure is possible over a large area.

Jenton have designed and made hundreds of UV conveyors.



Conveyor size

Conveyors available range from small, laboratory, benchtop systems to large, free standing production systems.



Jenton UV

Design

Design is carried out in house to suit customer requirements and all previous designs are available as templates.

Consideration is given to length, width, speed (variable), torque, airflow, cooling, lamp height (variable), infeed and outfeed connectivity, fan mounting, E-stops, interlocks, lamp control.

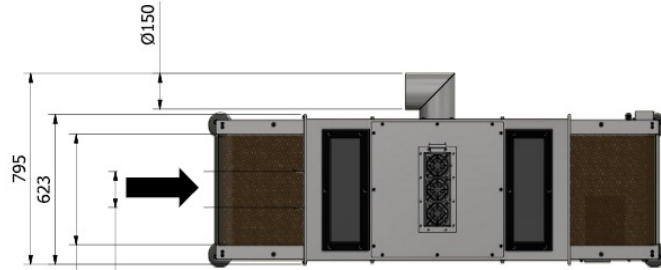

460 USABLE BELT WIDTH
150 PRODUCT GUIDE WIDTH

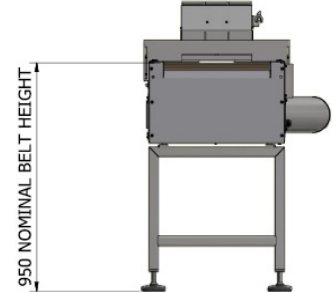
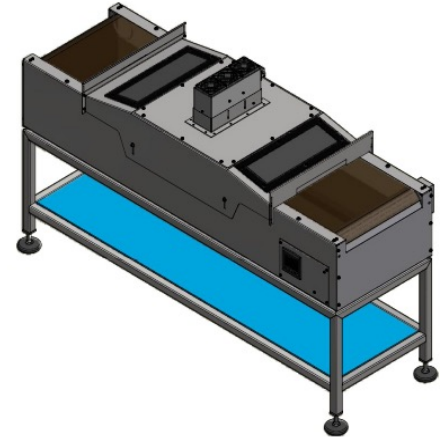
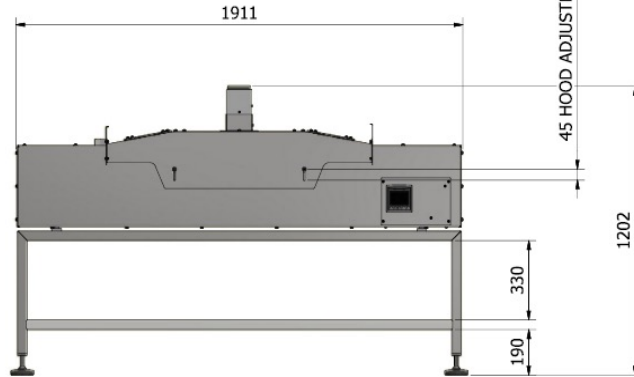

Jenton JA

Here are some examples of conveyors we have designed and made showing various features and including our own JA range of arc lamps.

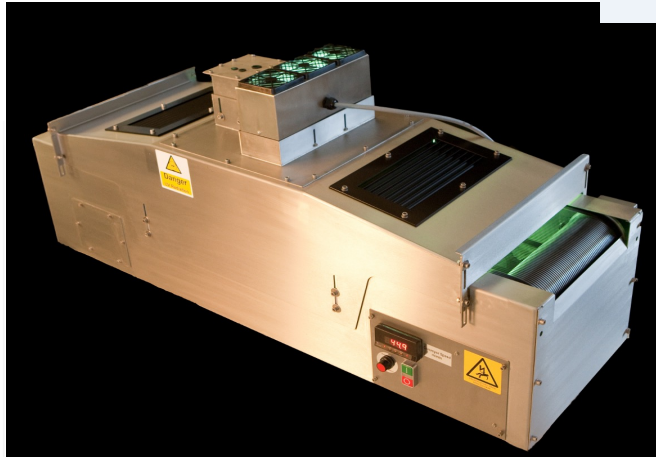
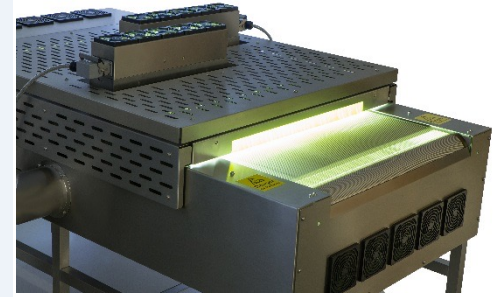

Design

Options include:

- Infeed/outfeed covers.
- Catch trays.
- UV monitoring.
- Heat shields.
- Floor stands.
- Fan mounting.



Other lamps

At *JentonUV* we have designed and made many conveyors to accommodate lamps from other manufacturers.

Excelitas

GEW

Xenon

Phoseon

Fusion

Nordson

Honle

Dymax



OEM

At **JentonUV** we can design and supply conveyors on an OEM basis – or to fit a lamp customers already have. Conveyors can be unbranded or branded with OEM logo.



Jenton UV

Sometimes a conveyor isn't the right solution

No problem. At JentonUV we also design and make all kinds of ovens, automatic systems and curing jigs. Just ask.





Jenton UV

Contact Us

Tel: +44 (0)1256 892194

Email: sales@jenton.co.uk

Visit: www.jentonuv.co.uk