

US-2500 MDM 700x360 50 mm

The leading banding machine for every need

A

Tech Specs

Weight net	124 kg ¹
Pallet size for shipment (Length x Width x Height)	120x80x155 cm (for 1 Machine)
Working height	849–1024 mm
Pneumatic connection	6 bar
Display languages	cs, da, de, en, es, fi, fr, it, nl, no, pl, pt, sv

Features

- ✓ High machine safety and easy accessibility
- ✓ Adjustable 5-inch touchscreen with intuitive operation and assistance
- ✓ Software update via USB stick
- ✓ Quick band changes through an innovative dispenser concept
- ✓ IIoT-Ready

Basic package

Nr.	Mechanical build
	✓ Arch size 700x360 mm (650064)
	✓ Colour standard ATS
	✓ Control unit V6
	✓ Housing standard square
155F1	✓ Air supported arch
156F1	✓ Dispenser motorised MDM

Nr.	Electrical build
	<input type="checkbox"/> Connection 200-240 V ~ 50-60 Hz
	<input type="checkbox"/> Connection 100-120 V ~ 50-60 Hz

Max. cycle time / min²

Arch	Min. Product ³	Max. Product ⁴
700x360	18	25

Options

Nr.	Mechanical options
119F1	<input type="checkbox"/> Print mark reader
150F0	<input type="checkbox"/> Sonotrode 41 mm mit ATS Logo
150F1	<input type="checkbox"/> Sonotrode 41 mm neutral
151F1	<input type="checkbox"/> Sonotrode 30 mm neutral

Nr.	Electrical options
101F0	<input type="checkbox"/> Exchange signals

Additional equipment

Nr.	Equipment
	✓ Foot pedal

¹ Weight of the base package (without additional options) with arch size 700x500

² With ideal infeed and machine settings

³ Dimension minimum product circumference = 100 mm

⁴ Dimension maximum product circumference generally 20 mm distance from arch

Layout example US-2500 MDM 700x500/30mm

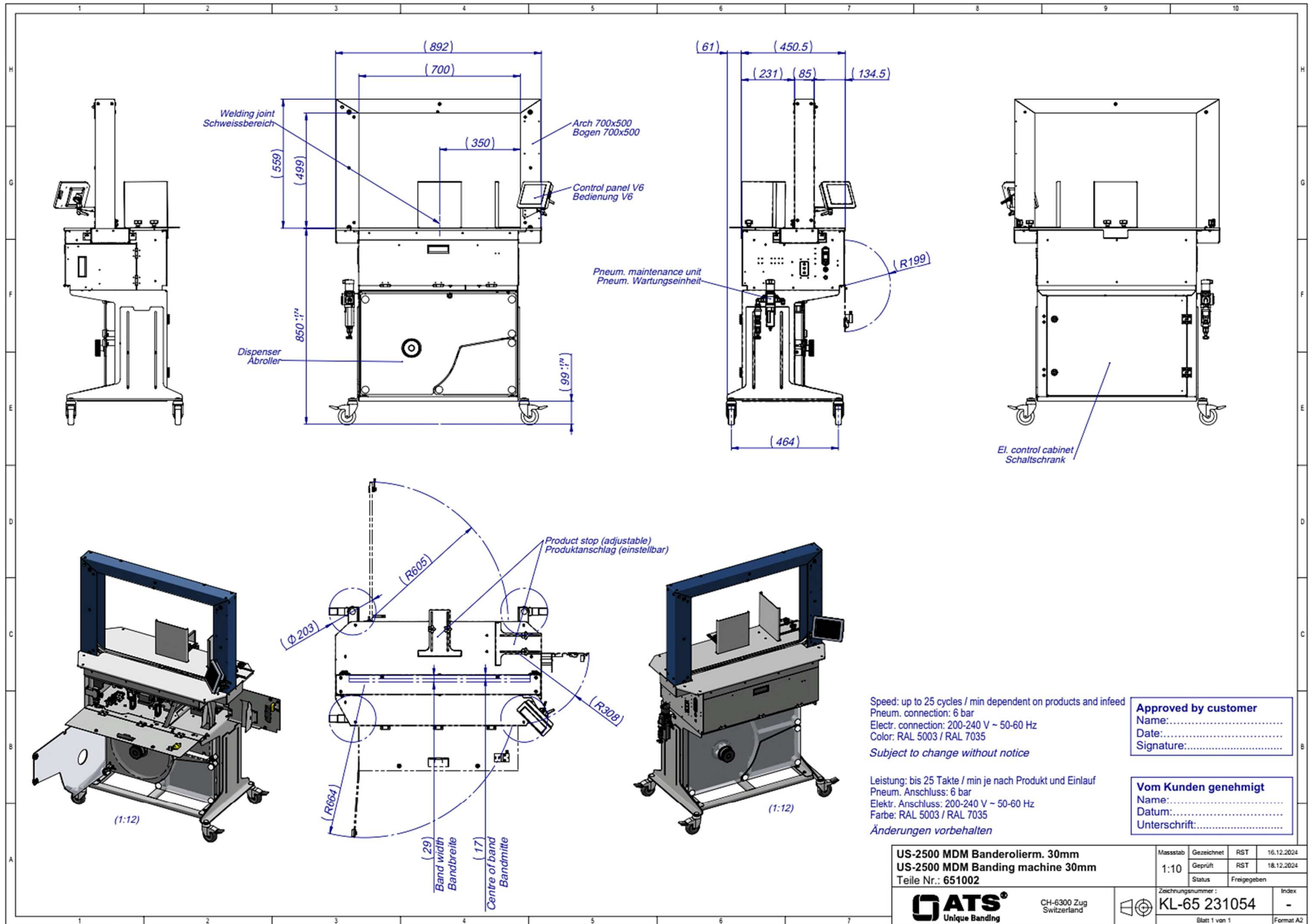

65 231054-MLA-8859v 1/19svoc, 18. Dezember 2024 07:46:59

History

Version	Date	Author	Reason for change / Remarks
00	20.03.2025	DAG	First edition