



Jenton Banding
Excellence in packaging automation

StraPack OB-360A

Paper and film tape banding machine

- Conveyor speed - 13m/ min
- Impeccable sealing technology
- Versatile - Runs 30mm wide paper or film tape
- Adjustable Tension – From 5 to 30N



Features and Benefits

High Speed

Conveyor Speed: 13m/min. Soft or elastic bundles can be banded without sacrificing speed.

Versatile

Applies banding to packages as small as 30mm wide x 10mm high, up to 480mm wide x 210mm high. Either paper or film tape can be used. The new track design allows the use of 60-100µm film, reducing cost and waste.

Fully Automated Operation

Supplied with 300mm wide belts for fully automated operation.

Impeccable Sealing

Sealing Design eliminates curling, folding or peeling of tape edges.

Optional Dispenser Unit

Optional dispenser unit for larger tape, or film reels minimises reel changes.

Arch Size	W 428 x H 216	
Dimension	Width	570mm
	Depth	564.6mm
	Height	488mm
	Weight	50kg
Table Height	237mm	
Minimum Package Size	W 100 x H 30mm	
Maximum Package Size	W 300 x H 200mm	
Maximum Pack Weight	5kg	
Tape	Paper - W 30mm x 190m 80g Film - W 30mm x 200 - 370m 60 - 110µm	
Strap Tension	5-30N (0.5 - 3kgf) adjustable	
Power Supply	100-120, 200-240 V 1 Phase 50 / 60 Hz	

Dimensions and specifications are subject to change without notice.

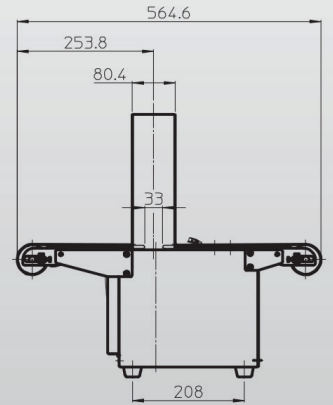
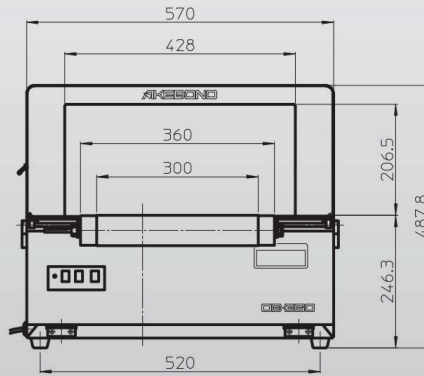
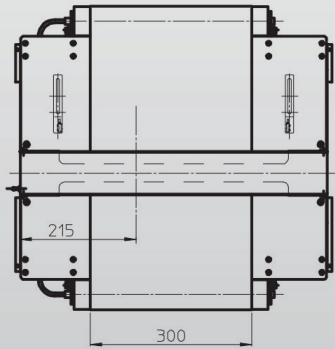

During the last 50 years The Jenton Group has become the go-to place for customers who want innovative and bespoke equipment that improves their production efficiency and process.

Contact us to find out more and discuss your requirements



Jenton Banding
Excellence in packaging automation

+44 (0) 1256 892194 | sales@jenton.co.uk
www.jentonbanding.co.uk